

02 耐圧防爆構造アダプター

Flameproof Adaptor

SA22-16~104-70型

d2

工場電気設備防爆指針
(ガス蒸気防爆2006)

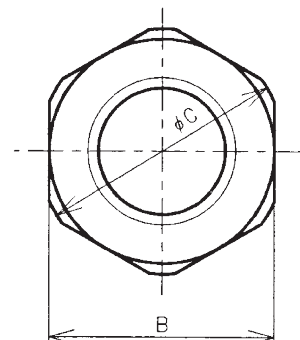
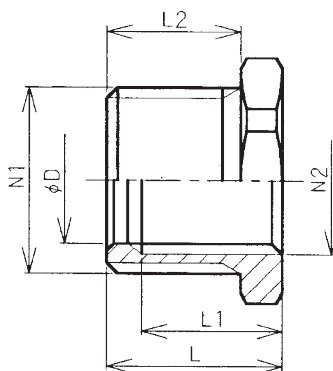

主材質 Material	鋼 Steel
表面処理 Surface Treatment	電気亜鉛メッキ Zn Electroplating

●1段 1step

型式 Type	N1	N2	φD	B	φC	L1	L2	L	重量(kg) Weight
SA22-16	PF 3/4	PF 1/2	16	32	35	22	19	25	0.05
SA28-22	PF 1	PF 3/4	24.1	35	38	20	21	26	0.07
SA36-28	PF 1-1/4	PF 1	30.3	46	50	20	21	26	0.12
SA42-36	PF 1-1/2	PF 1-1/4	39	50	54	20	21	26	0.12
SA54-42	PF 2	PF 1-1/2	44.8	63	67	20	21	26	0.24
SA70-54	PF 2-1/2	PF 2	56.7	77	80	22	22	28	0.43
SA82-70	PF 3	PF 2-1/2	72.2	91	94	25	25	32	0.50
SA92-82	PF 3-1/2	PF 3	84.9	105	109	25	25	32	0.56
SA104-92	PF 4	PF 3-1/2	97.4	115	119	25	25	32	0.68

●2段 2step

型式 Type	N1	N2	φD	B	φC	L1	L2	L	重量(kg) Weight
SA28-16	PF 1	PF 1/2	16	35	38	20	21	26	0.10
SA36-22	PF 1-1/4	PF 3/4	24.1	46	50	20	21	26	0.17
SA42-28	PF 1-1/2	PF 1	30.3	50	54	20	21	26	0.19
SA54-36	PF 2	PF 1-1/4	39	63	67	20	21	26	0.29
SA70-42	PF 2-1/2	PF 1-1/2	44.8	77	80	22	22	28	0.60
SA82-54	PF 3	PF 2	56.7	91	94	25	25	32	0.85
SA92-70	PF 3-1/2	PF 2-1/2	72.2	105	109	25	25	32	0.93
SA104-82	PF 4	PF 3	84.9	115	119	25	25	32	1.10

●3段 3step

型式 Type	N1	N2	φD	B	φC	L1	L2	L	重量(kg) Weight
SA36-16	PF 1-1/4	PF 1/2	16	46	50	20	21	26	0.21
SA42-22	PF 1-1/2	PF 3/4	24.1	50	54	20	21	26	0.25
SA54-28	PF 2	PF 1	30.3	63	67	20	21	26	0.40
SA70-36	PF 2-1/2	PF 1-1/4	39	77	80	22	22	28	0.66
SA82-42	PF 3	PF 1-1/2	44.8	91	94	25	25	32	1.10
SA92-54	PF 3-1/2	PF 2	56.7	105	109	25	25	32	1.32
SA104-70	PF 4	PF 2-1/2	72.2	115	119	25	25	32	1.43