

02

耐圧防爆構造ニップル・90°エルボ

Flameproof Nipple・90 Degree Elbow

SNP-16~104型

d2

工場電気設備防爆指針
(ガス蒸気防爆2006)

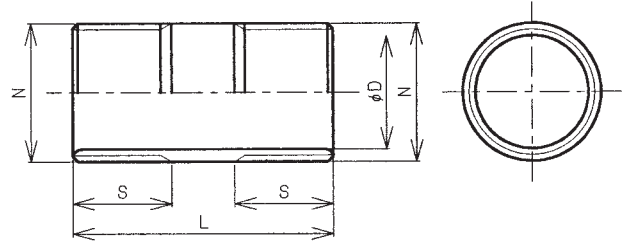

主材質 Material	炭素鋼管(ステンレス鋼も可) Carbon Steel Pipe (Stainless Steel is applied upon order)
表面処理 Surface Treatment	電気亜鉛メッキ Zn Electroplating

型式 Type	N	φD	S	L	重量(kg) Weight
SNP-16	PF 1/2	16.1	19	50	0.05
SNP-22	PF 3/4	21.6	19	50	0.06
SNP-28	PF 1	27.6	23	61	0.10
SNP-36	PF 1-1/4	35.7	23	61	0.14
SNP-42	PF 1-1/2	41.6	23	61	0.16
SNP-54	PF 2	52.9	25	65	0.21
SNP-70	PF 2-1/2	67.9	25	65	0.30
SNP-82	PF 3	80.7	30	80	0.45
SNP-92	PF 3-1/2	93.2	35	90	0.64
SNP-104	PF 4	105.3	35	90	1.27

SSE-16~28型

d2

工場電気設備防爆指針
(ガス蒸気防爆2006)

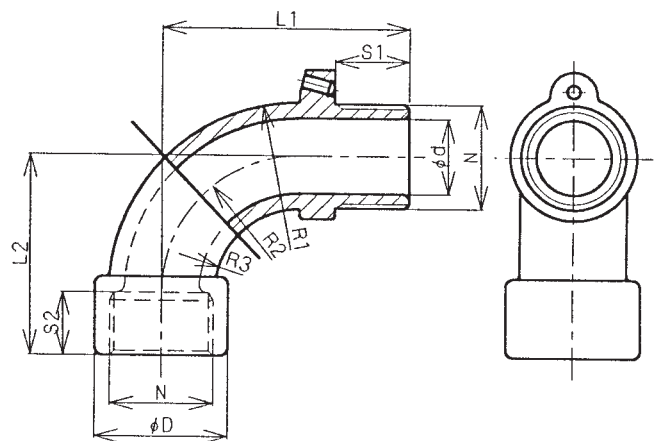

主材質 Material	アルミニウム合金鋳物 Aluminum Alloy Casting
-----------------	--------------------------------------

型式 Type	N	φD	φd	S1	S2	L1	L2	R1	R2	R3	重量(kg) Weight
SSE-16	PF 1/2	27	15	19	16	56	44	39.5	28	16.5	0.02
SSE-22	PF 3/4	34	19	19	16	63	51	48.5	35	21.5	0.08
SSE-28	PF 1	43	24	24	20	77	64	61	44	27	0.14

カタログの記載内容は、お断りなく変更する場合がありますのでご了承ください。
Please note that the contents of the catalog are subject to change without notice.