

02

耐圧防爆構造ジャンクションボックス Flameproof Junction Box

SGT-16H~54H 型

d2

工場電気設備防爆指針
(ガス蒸気防爆2006)

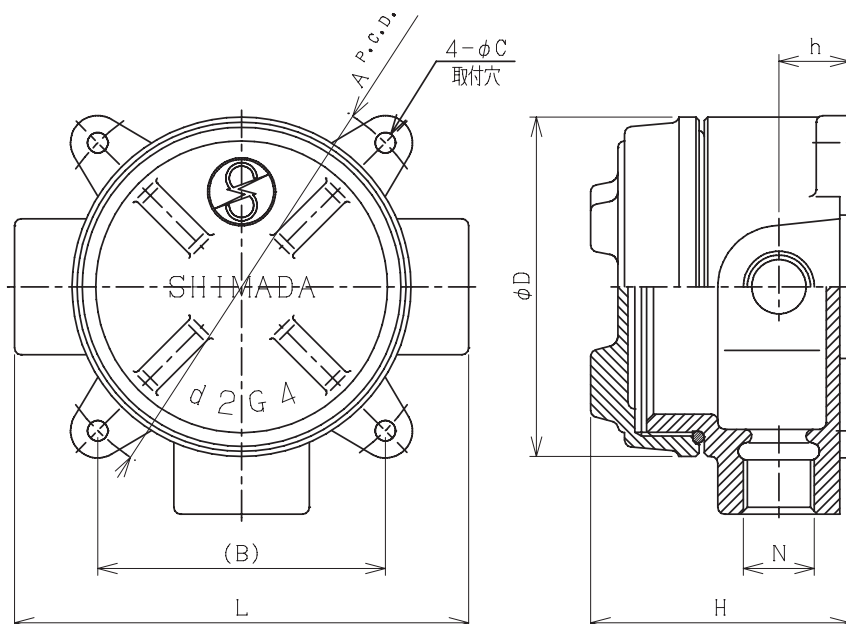
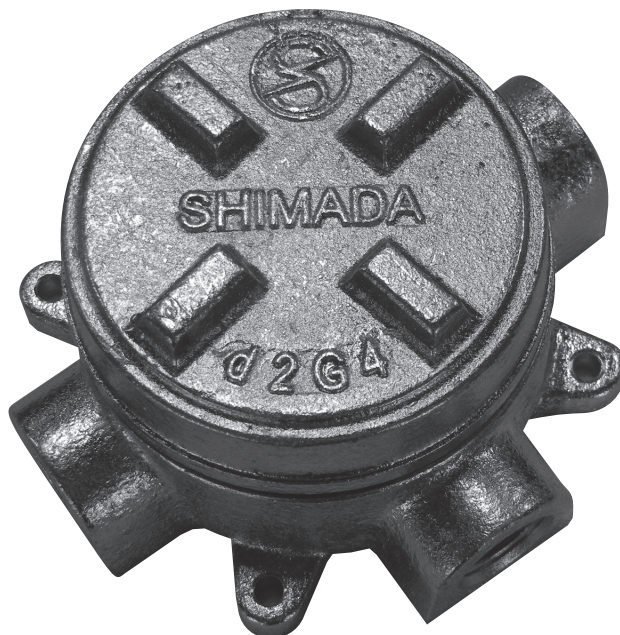

主材質 Material	鋳鉄 Cast Iron
表面処理 Surface Treatment	熔融亜鉛メッキ Hot Dip Galvanized

型式 Type	N	A	(B)	φC	φD	h	H	L	重量(kg) Weight
SGT-16H	PF 1/2	120	85	6	100	21	78	134	1.8
SGT-22H	PF 3/4	120	85	6	100	21	78	134	1.8
SGT-28H	PF 1	120	85	6	100	30	94	134	2.1
SGT-36H	PF 1-1/4	145	103	9	125	33	110	161	4.4
SGT-42H	PF 1-1/2	145	103	9	125	40	122	161	3.9
SGT-54H	PF 2	180	127	9	160	50	142	196	7.5

SGX-16H~54H型

d2

工場電気設備防爆指針
(ガス蒸気防爆2006)

02

配管付属品

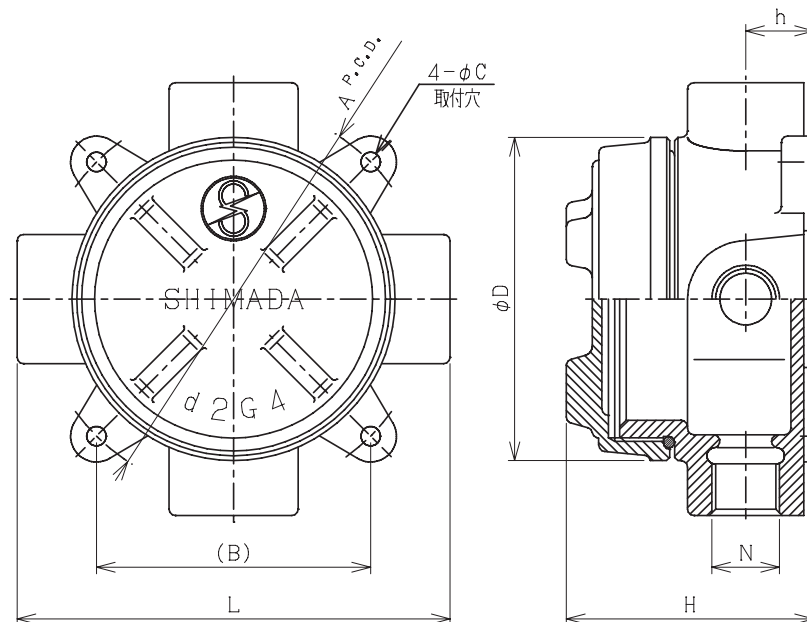
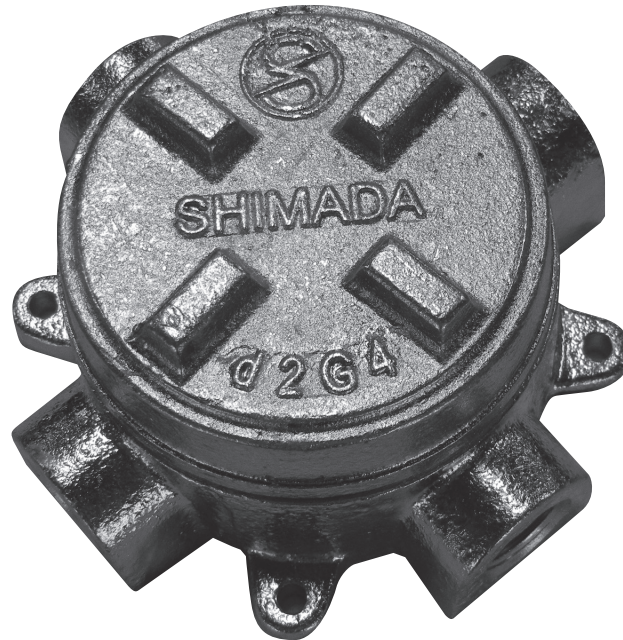

主材質 Material	鑄鉄 Cast Iron
表面处理 Surface Treatment	熔融亜鉛メッキ Hot Dip Galvanized

型式 Type	N	A	(B)	φC	φD	h	H	L	重量(kg) Weight
SGX-16H	PF 1/2	120	85	6	100	21	78	134	1.8
SGX-22H	PF 3/4	120	85	6	100	21	78	134	1.8
SGX-28H	PF 1	120	85	6	100	30	94	134	2.1
SGX-36H	PF 1-1/4	145	103	9	125	33	110	161	4.4
SGX-42H	PF 1-1/2	145	103	9	125	40	122	161	3.9
SGX-54H	PF 2	180	127	9	160	50	142	196	7.5

02

耐圧防爆構造ジャンクションボックス(ドーム型) Flameproof Junction Box

SGT-16DH~54DH型

d2

工場電気設備防爆指針
(ガス蒸気防爆2006)

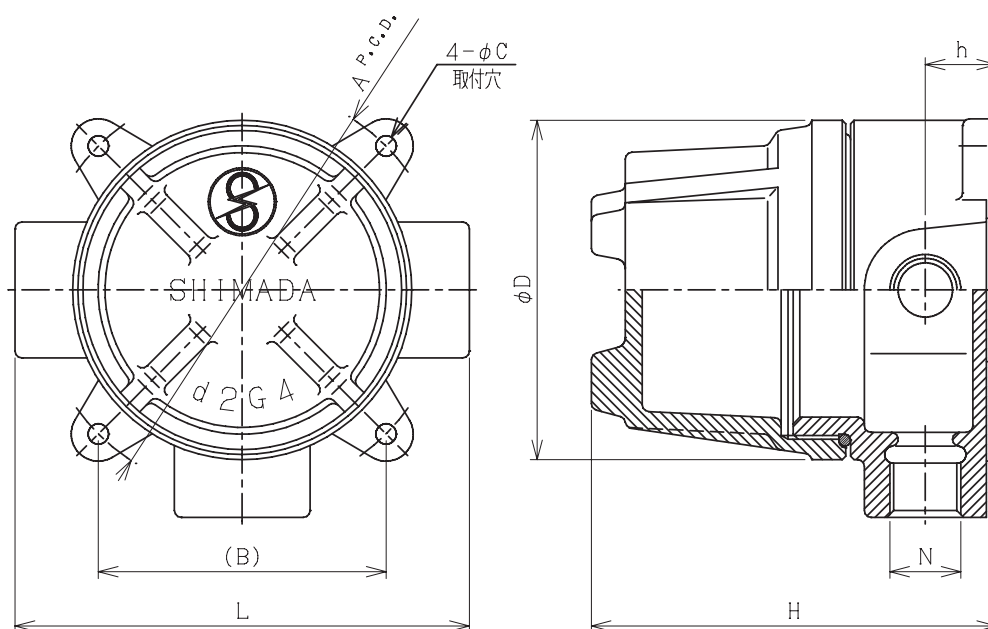
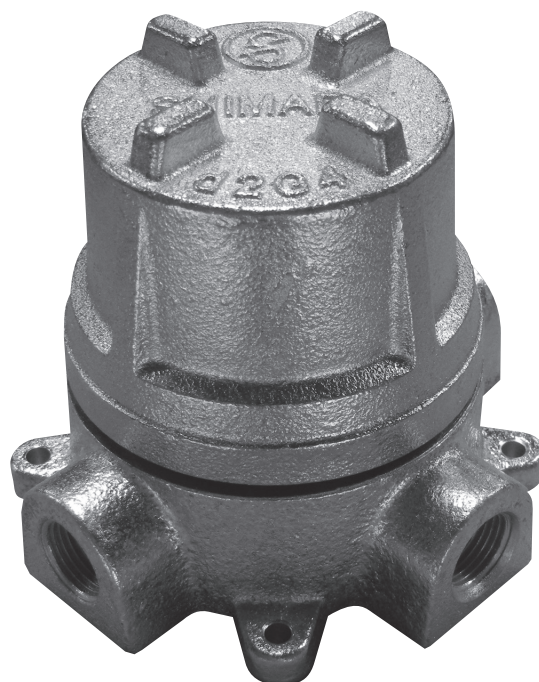

型式 Type	N	A	(B)	φC	φD	h	H	L	重量(kg) Weight
SGT-16DH	PF 1/2	120	85	6	100	21	120	134	2.1
SGT-22DH	PF 3/4	120	85	6	100	21	120	134	2.1
SGT-28DH	PF 1	120	85	6	100	30	140	134	2.4
SGT-36DH	PF 1-1/4	145	103	9	125	33	160	161	4.7
SGT-42DH	PF 1-1/2	145	103	9	125	40	160	161	4.4
SGT-54DH	PF 2	180	127	9	160	50	185	196	8.2

主材質 Material	鋳鉄 Cast Iron
表面処理 Surface Treatment	溶融亜鉛メッキ Hot Dip Galvanized

SGX-16DH~54DH型

d2

工場電気設備防爆指針
(ガス蒸気防爆2006)

02

配管付属品

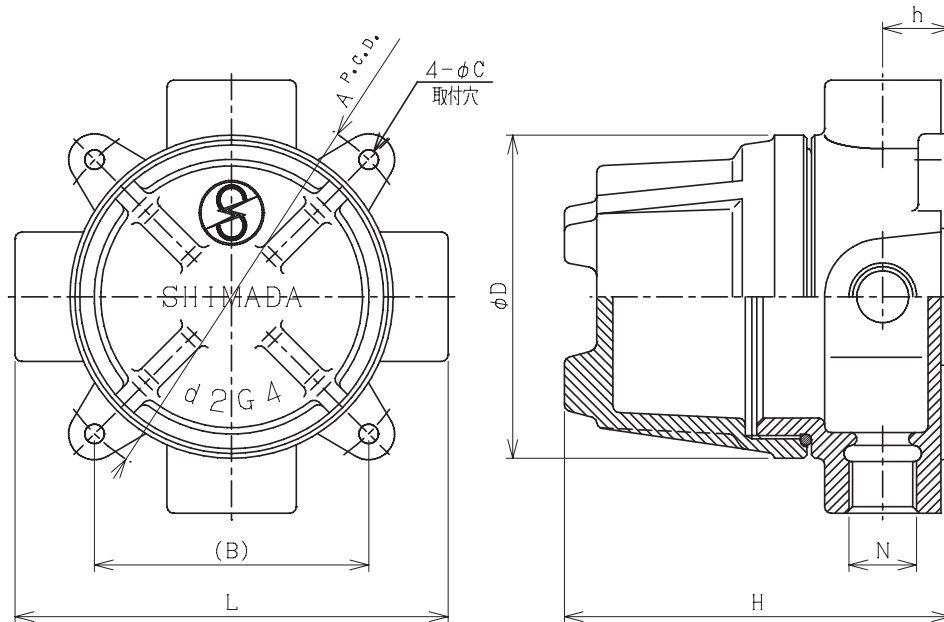

主材質 Material	鑄鉄 Cast Iron
表面处理 Surface Treatment	熔融亜鉛メッキ Hot Dip Galvanized

型式 Type	N	A	(B)	φC	φD	h	H	L	重量(kg) Weight
SGX-16DH	PF 1/2	120	85	6	100	21	120	134	2.1
SGX-22DH	PF 3/4	120	85	6	100	21	120	134	2.1
SGX-28DH	PF 1	120	85	6	100	30	140	134	2.4
SGX-36DH	PF 1-1/4	145	103	9	125	33	160	161	4.7
SGX-42DH	PF 1-1/2	145	103	9	125	40	160	161	4.4
SGX-54DH	PF 2	180	127	9	160	50	185	196	8.2