

02

耐圧防爆構造レジュューサー

Flameproof Reduser

SR16-22~70-104型

d2

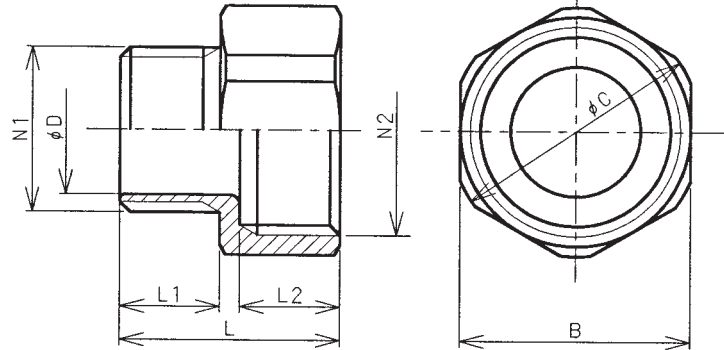

主材質 Material	鋼(ステンレス鋼・黄銅も可) Steel (Stainless steel and brass are applied upon order)
表面処理 Surface treatment	電気亜鉛メッキ Zn electroplating

●1段 1step

型式 Type	N1	N2	φD	B	φC	L1	L2	L	重量(kg) Weight
SR16-22	PF 1/2	PF 3/4	15	32	35	16	16	35	0.08
SR22-28	PF 3/4	PF 1	20	38	41	16	20	40	0.12
SR28-36	PF 1	PF 1-1/4	26	46	50	20	20	44	0.24
SR36-42	PF 1-1/4	PF 1-1/2	34	54	58	20	20	44	0.28
SR42-54	PF 1-1/2	PF 2	39	67	73	20	20	44	0.32
SR54-70	PF 2	PF 2-1/2	51	82	85	20	20	44	0.35
SR70-82	PF 2-1/2	PF 3	62	99	103	25	25	56	0.79
SR82-92	PF 3	PF 3-1/2	79	110	114	25	25	56	0.91
SR92-104	PF 3-1/2	PF 4	88	124	128	25	25	56	1.14

●2段 2step

型式 Type	N1	N2	φD	B	φC	L1	L2	L	重量(kg) Weight
SR16-28	PF 1/2	PF 1	15	38	41	16	20	40	0.11
SR22-36	PF 3/4	PF 1-1/4	20	46	50	16	20	40	0.14
SR28-42	PF 1	PF 1-1/2	26	54	58	20	20	44	0.21
SR36-54	PF 1-1/4	PF 2	34	67	73	20	20	44	0.33
SR42-70	PF 1-1/2	PF 2-1/2	39	82	85	20	20	44	0.40
SR54-82	PF 2	PF 3	51	99	103	25	25	56	0.68
SR70-92	PF 2-1/2	PF 3-1/2	67	110	114	25	25	56	0.98
SR82-104	PF 3	PF 4	79	124	128	25	25	56	1.12

●3段 3step

型式 Type	N1	N2	φD	B	φC	L1	L2	L	重量(kg) Weight
SR16-36	PF 1/2	PF 1-1/4	15	46	50	16	20	40	0.14
SR22-42	PF 3/4	PF 1-1/2	20	54	58	16	20	40	0.20
SR28-54	PF 1	PF 2	26	67	73	20	20	44	0.31
SR36-70	PF 1-1/4	PF 2-1/2	34	82	85	20	20	44	0.40
SR42-82	PF 1-1/2	PF 3	39	99	103	25	25	56	0.65
SR54-92	PF 2	PF 3-1/2	51	110	114	25	25	56	0.70
SR70-104	PF 2-1/2	PF 4	67	124	128	25	25	56	1.13

※3段以上も製作出来ますので、お問合せください。

※3steps or more can be produced upon order.

02

配管付属品