

02

耐圧防爆構造シーリングフィッティング Flameproof Sealing Fitting

SFT-16H~28H型 (縦型)

d2

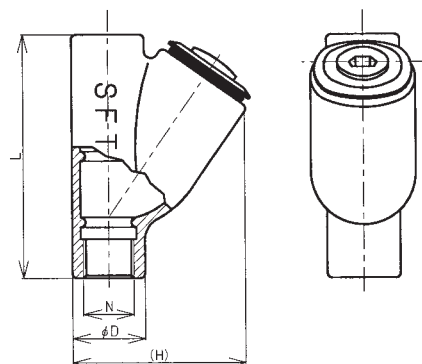

主材質 Material	鑄鉄 Cast iron
表面処理 Surface treatment	溶融亜鉛メッキ Hot dip galvanized

型式 Type	N	φD	(H)	L	重量 (kg) Weight
SFT-16H	PF 1/2	30	72	100	0.6
SFT-22H	PF 3/4	35	77	100	0.7
SFT-28H	PF 1	43	89	110	0.8

SFT-36H~104H型 (縦型)

d2

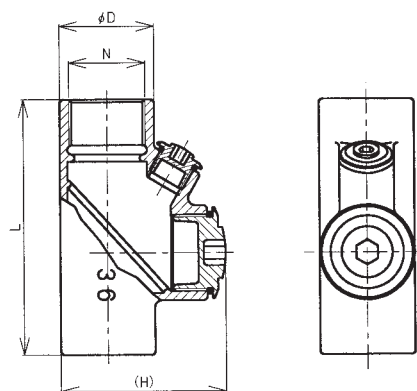

主材質 Material	鑄鉄 Cast iron
表面処理 Surface treatment	溶融亜鉛メッキ Hot dip galvanized

型式 Type	N	φD	(H)	L	重量 (kg) Weight
SFT-36H	PF 1-1/4	52	90	140	1.1
SFT-42H	PF 1-1/2	60	94	145	1.2
SFT-54H	PF 2	72	113	155	1.7
SFT-70H	PF 2-1/2	88	140	170	3.2
SFT-82H	PF 3	102	152	190	3.1
SFT-92H	PF 3-1/2	116	166	190	4.3
SFT-104H	PF 4	133	178	224	7.1

SFG-16H~104H型(自在型)

d2

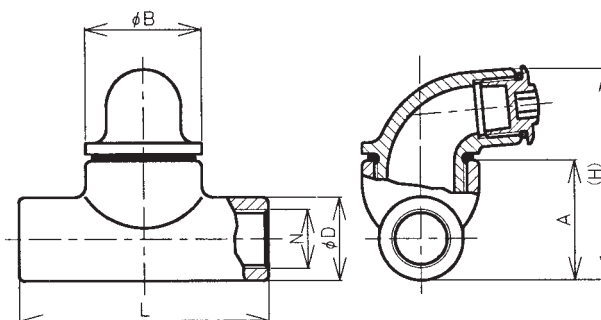

主材質 Material	鑄鉄 Cast iron
表面処理 Surface treatment	熔融亜鉛メッキ Hot dip galvanized

型式 Type	N	φD	A	φB	(H)	L	重量(kg) Weight
SFG-16H	PF 1/2	30	43	42	75	90	0.6
SFG-22H	PF 3/4	35	48	42	80	90	0.5
SFG-28H	PF 1	42	56	42	88	100	0.6
SFG-36H	PF 1-1/4	52	67	52	108	120	1.0
SFG-42H	PF 1-1/2	60	75	52	116	130	1.1
SFG-54H	PF 2	72	87	52	128	150	1.7
SFG-70H	PF 2-1/2	88	110	75	161	165	3.3
SFG-82H	PF 3	102	125	75	176	180	4.3
SFG-92H	PF 3-1/2	114	132	100	187	200	6.5
SFG-104H	PF 4	130	151	100	206	220	7.6

SFD-16H~104H型(ドレン型)

d2

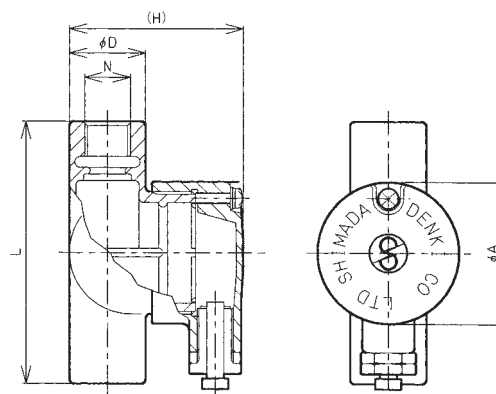

主材質 Material	鑄鉄 Cast iron
表面処理 Surface treatment	熔融亜鉛メッキ Hot dip galvanized

型式 Type	N	φD	φA	(H)	L	重量(kg) Weight
SFD-16H	PF 1/2	35	65	81	120	1.1
SFD-22H	PF 3/4	35	65	81	120	1.0
SFD-28H	PF 1	45	65	93	130	1.2
SFD-36H	PF 1-1/4	52	80	107	140	1.6
SFD-42H	PF 1-1/2	60	80	115	160	2.0
SFD-54H	PF 2	70	80	124	190	2.4
SFD-70H	PF 2-1/2	88	80	139	165	4.0
SFD-82H	PF 3	102	80	154	180	4.1
SFD-92H	PF 3-1/2	114	110	177	200	6.6
SFD-104H	PF 4	130	110	196	220	7.8

02

配管付属品