

02

安全増防爆構造分岐ボックス

Increased Safety Branch Box

ISE28×2-16×2H型

e



重量：0.7kg
Weight

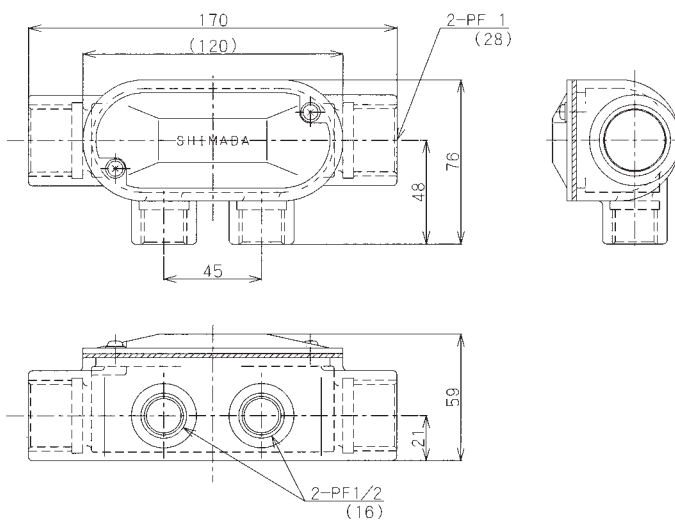

主材質 Material	本体：鋳鉄 Body Cast iron
	カバー：鋼板 Cover Steel Sheet
表面処理 Surface treatment	溶融亜鉛メッキ Hot dip galvanized

ISE28-16×2H型

e



重量：0.6kg
Weight

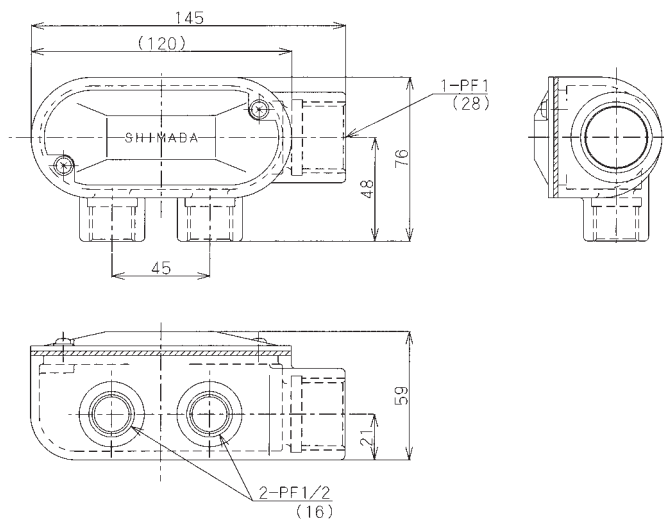

主材質 Material	本体：鋳鉄 Body Cast iron
	カバー：鋼板 Cover Steel Sheet
表面処理 Surface treatment	溶融亜鉛メッキ Hot dip galvanized

ISE28×2-16×3H型

e

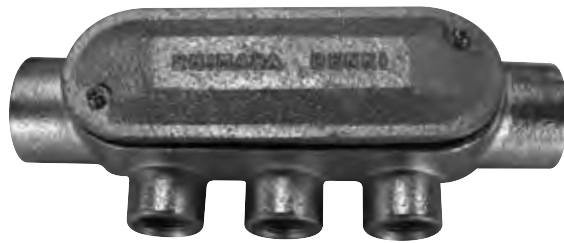

重量：0.8kg
Weight

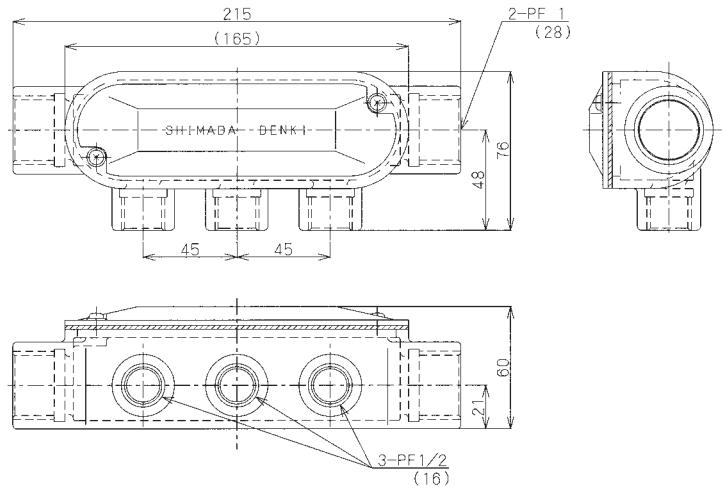

主材質 Material	鑄鉄 Cast iron
表面处理 Surface treatment	熔融亜鉛メッキ Hot dip galvanized

ISE28-16×3H型

e



重量：0.7kg
Weight

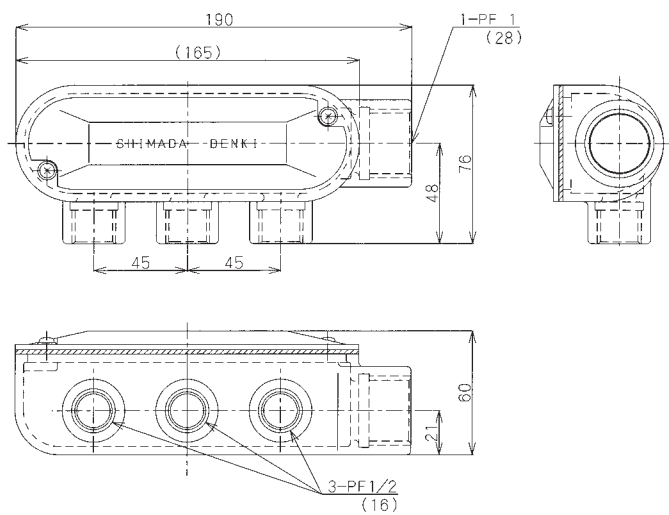

主材質 Material	鑄鉄 Cast iron
表面处理 Surface treatment	熔融亜鉛メッキ Hot dip galvanized

02

配管付属品