

02

安全増防爆構造エルボ・チーズ

Increased Safety Elbow and Tee

ISEB-16H~54H型 (90°背蓋)

e

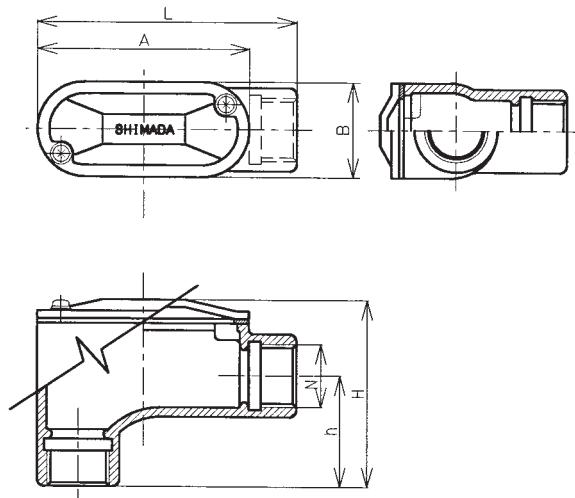

主材質 Material	本体：鋳鉄 Body Cast iron
	カバー：鋼板 Cover Steel Sheet
表面処理 Surface treatment	溶融亜鉛メッキ Hot dip galvanized

型式 Type	N	A	B	h	H	L	重量(kg) Weight
ISEB-16H	PF 1/2	90	40	49	79	110	0.5
ISEB-22H	PF 3/4	90	40	47	79	110	0.6
ISEB-28H	PF 1	120	56	65	103	145	1.0
ISEB-36H	PF 1-1/4	120	56	65	108	145	1.4
ISEB-42H	PF 1-1/2	150	76	85	134	180	2.2
ISEB-54H	PF 2	150	76	85	140	180	2.7

ISEL-16H~54H型 (左90°横蓋)

e

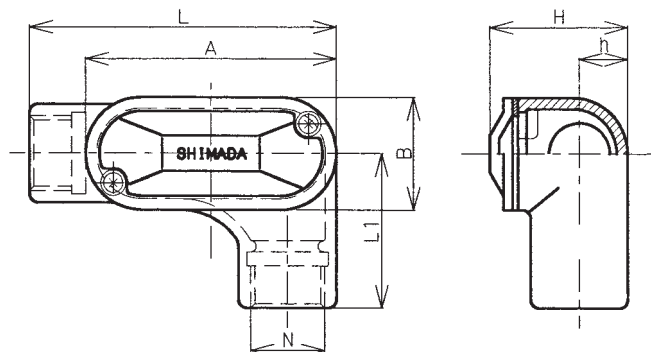

主材質 Material	本体：鑄鉄 Body Cast iron
	カバー：鋼板 Cover Steel Sheet
表面処理 Surface treatment	熔融亜鉛メッキ Hot dip galvanized

型式 Type	N	A	B	h	H	L1	L	重量 (kg) Weight
ISEL-16H	PF 1/2	90	40	15	45	55	110	0.5
ISEL-22H	PF 3/4	90	40	17.5	50	55	110	0.6
ISEL-28H	PF 1	120	56	21	59	70	145	1.0
ISEL-36H	PF 1-1/4	120	56	26	69	70	145	1.4
ISEL-42H	PF 1-1/2	150	76	30	79	90	180	2.2
ISEL-54H	PF 2	150	76	36	91	90	180	2.7

ISER-16H~54H型 (右90°横蓋)

e

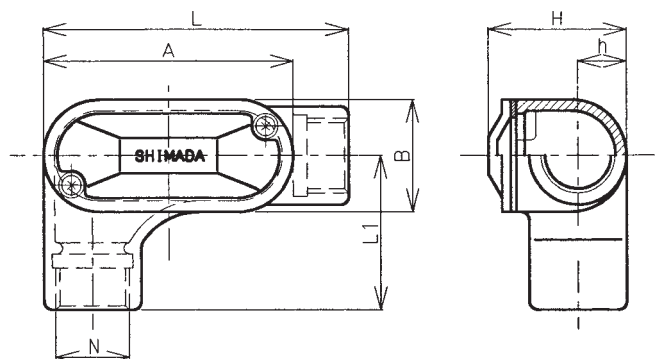

主材質 Material	本体：鑄鉄 Body Cast iron
	カバー：鋼板 Cover Steel Sheet
表面処理 Surface treatment	熔融亜鉛メッキ Hot dip galvanized

型式 Type	N	A	B	h	H	L1	L	重量 (kg) Weight
ISER-16H	PF 1/2	90	40	15	45	55	110	0.5
ISER-22H	PF 3/4	90	40	17.5	50	55	110	0.6
ISER-28H	PF 1	120	56	21	59	70	145	1.0
ISER-36H	PF 1-1/4	120	56	26	69	70	145	1.4
ISER-42H	PF 1-1/2	150	76	30	79	90	180	2.2
ISER-54H	PF 2	150	76	36	91	90	180	2.7

02

配管付属品

02

安全増防爆構造エルボ・チーズ

Increased Safety Elbow and Tee

ISEY-16H~54H型 (45°背蓋)

e

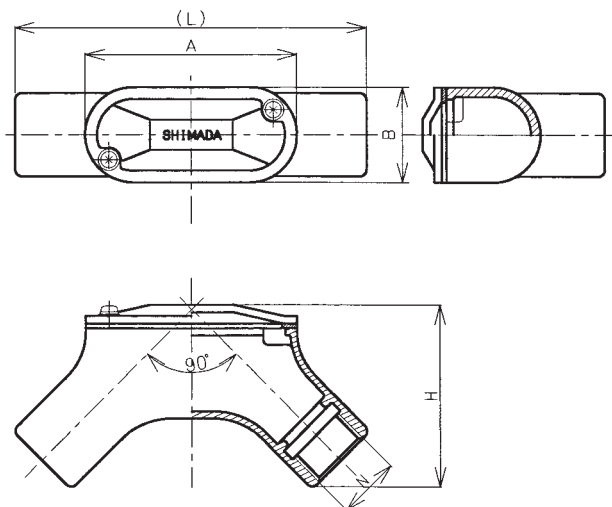

主材質 Material	本体：鋳鉄 Body Cast iron
	カバー：鋼板 Cover Steel Sheet
表面処理 Surface treatment	溶融亜鉛メッキ Hot dip galvanized

型式 Type	N	A	B	H	(L)	重量(kg) Weight
ISEY-16H	PF 1/2	90	40	74	145	0.5
ISEY-22H	PF 3/4	90	40	77	150	0.6
ISEY-28H	PF 1	120	56	92	180	1.0
ISEY-36H	PF 1-1/4	120	56	98	190	1.2
ISEY-42H	PF 1-1/2	150	76	118	230	2.3
ISEY-54H	PF 2	150	76	127	248	2.9

ISEYB-16H~54H型 (45°横蓋)

e

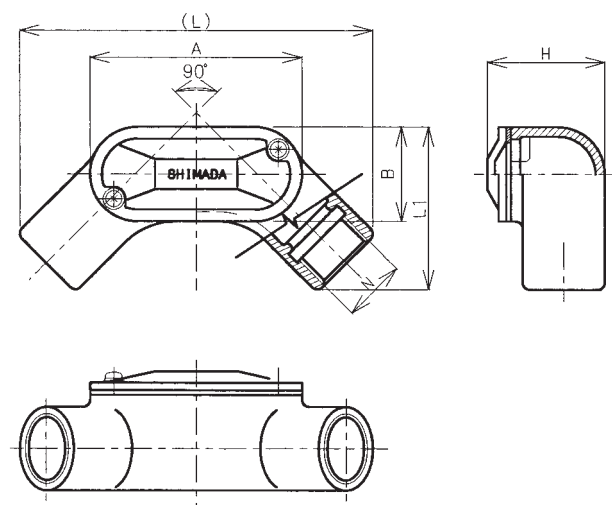

主材質 Material	本体：鋳鉄 Body Cast iron
	カバー：鋼板 Cover Steel Sheet
表面処理 Surface treatment	溶融亜鉛メッキ Hot dip galvanized

型式 Type	N	A	B	H	L1	(L)	重量(kg) Weight
ISEYB-16H	PF 1/2	90	40	45	69	145	0.5
ISEYB-22H	PF 3/4	90	40	50	69	150	0.6
ISEYB-28H	PF 1	120	56	59	89	180	1.0
ISEYB-36H	PF 1-1/4	120	56	69	91	190	1.2
ISEYB-42H	PF 1-1/2	150	76	79	115	230	2.3
ISEYB-54H	PF 2	150	76	91	130	248	2.9

ISEF-16H~54H型(背蓋)

e

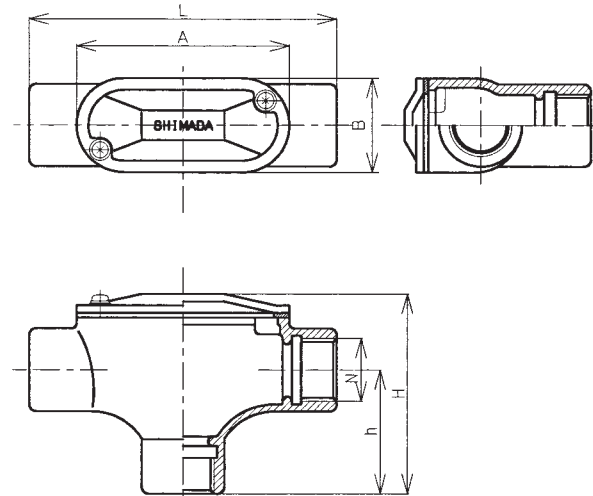

主材質 Material	本体：鑄鉄 Body Cast iron
	カバー：鋼板 Cover Steel Sheet
表面処理 Surface treatment	熔融亜鉛メッキ Hot dip galvanized

型式 Type	N	A	B	h	H	L	重量(kg) Weight
ISEF-16H	PF 1/2	90	40	49	79	130	0.7
ISEF-22H	PF 3/4	90	40	51.5	84	130	0.7
ISEF-28H	PF 1	120	56	65	103	170	1.2
ISEF-36H	PF 1-1/4	120	56	70	113	170	1.5
ISEF-42H	PF 1-1/2	150	76	85	134	210	2.8
ISEF-54H	PF 2	150	76	85	140	210	3.0

ISET-16H~54H型(横蓋)

e

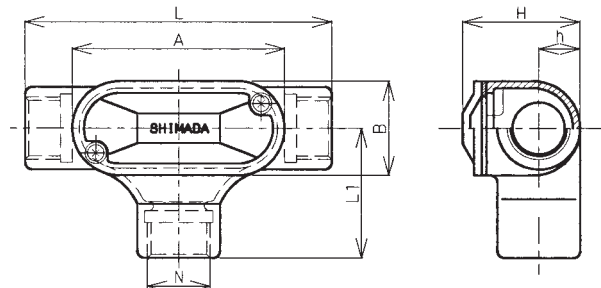

主材質 Material	本体：鑄鉄 Body Cast iron
	カバー：鋼板 Cover Steel Sheet
表面処理 Surface treatment	熔融亜鉛メッキ Hot dip galvanized

型式 Type	N	A	B	h	H	L1	L	重量(kg) Weight
ISET-16H	PF 1/2	90	40	15	45	55	130	0.7
ISET-22H	PF 3/4	90	40	17.5	50	55	130	0.7
ISET-28H	PF 1	120	56	21	59	70	170	1.2
ISET-36H	PF 1-1/4	120	56	26	69	70	170	1.5
ISET-42H	PF 1-1/2	150	76	30	79	90	210	2.8
ISET-54H	PF 2	150	76	36	91	90	210	3.0

02

配管付属品